

po wykowaniu naddatek upalić na wyciśle i rązować do spawania

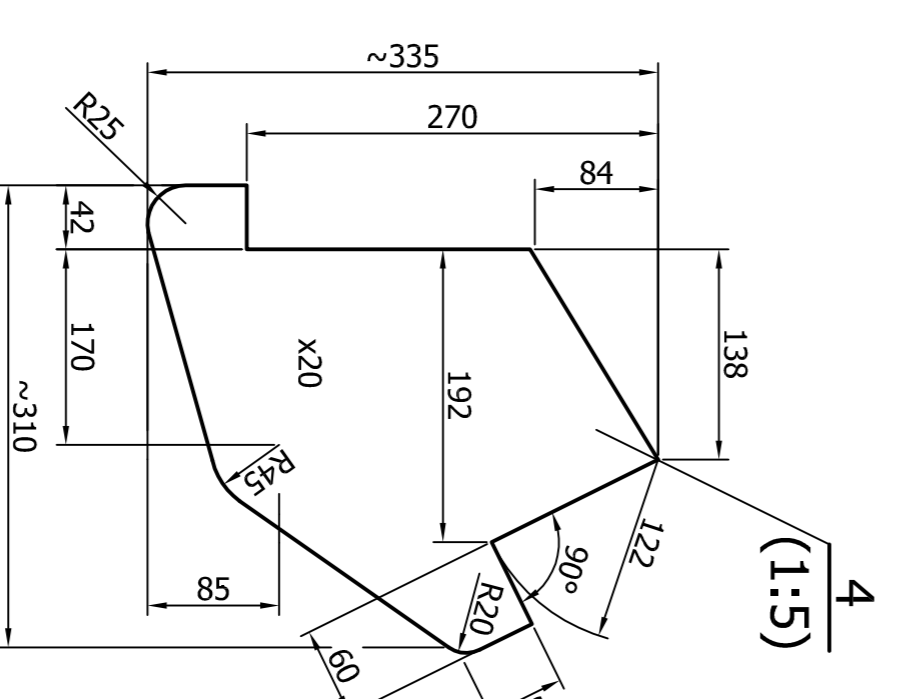
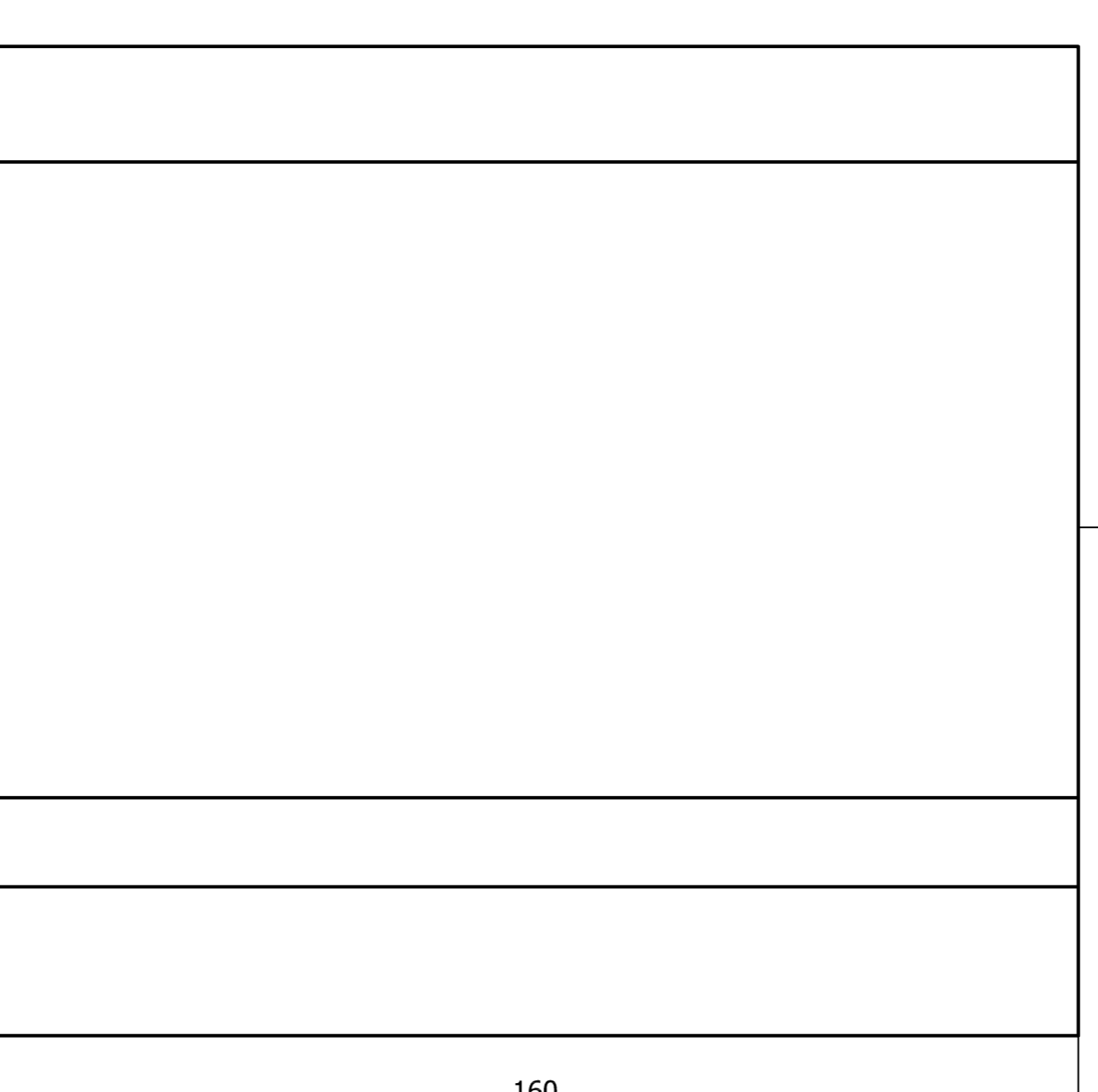
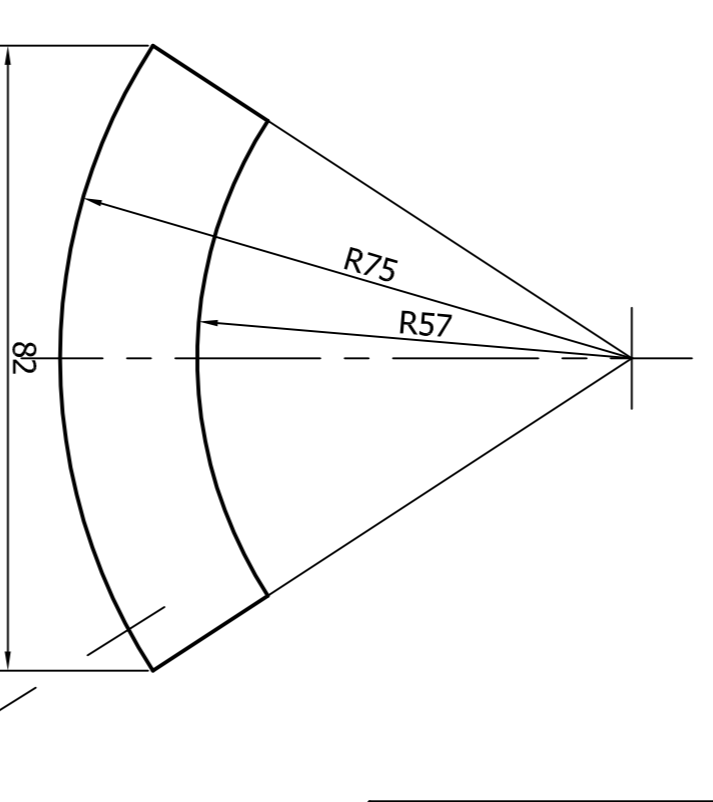
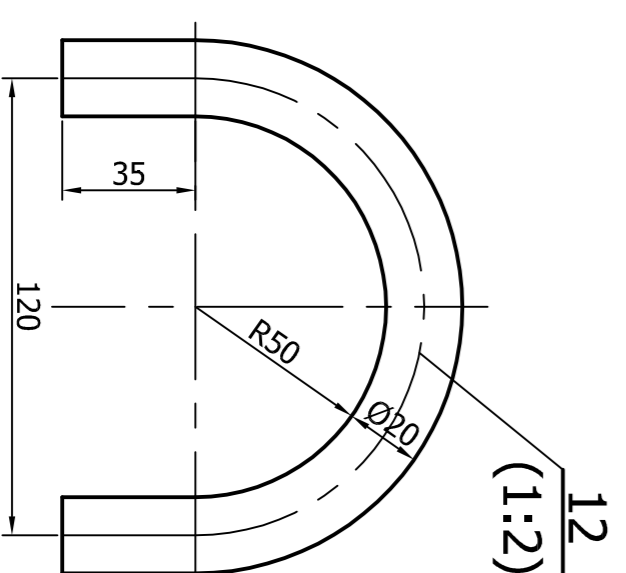
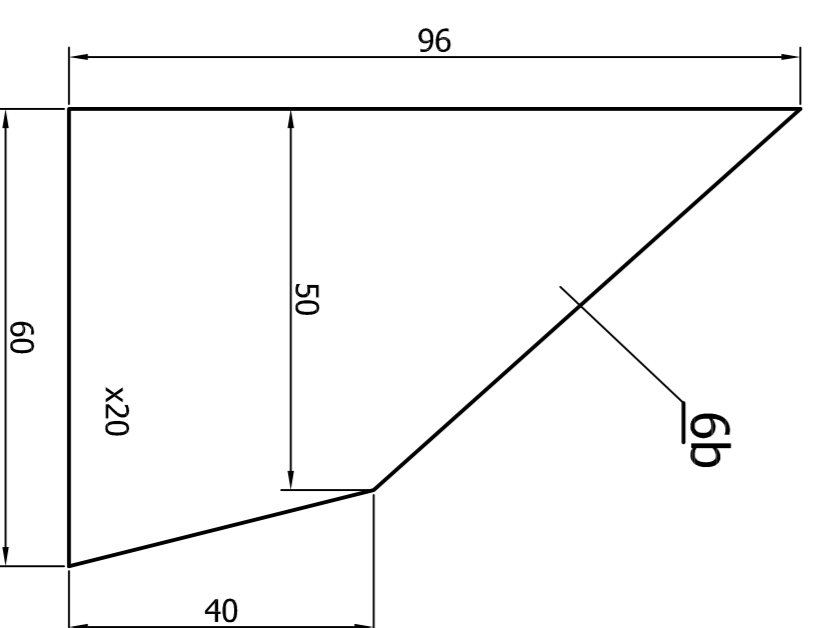
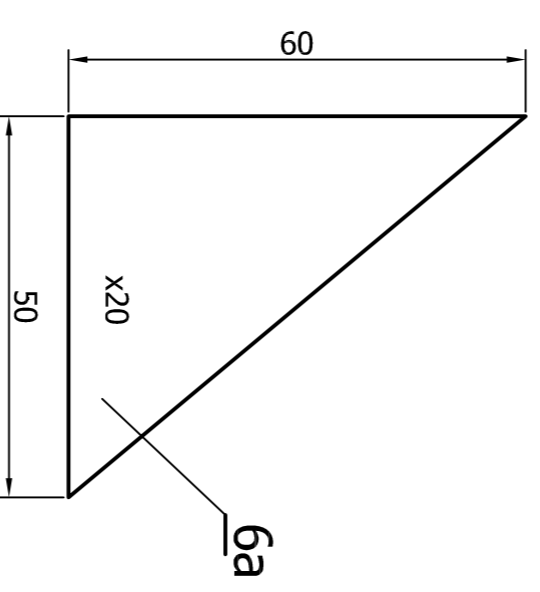
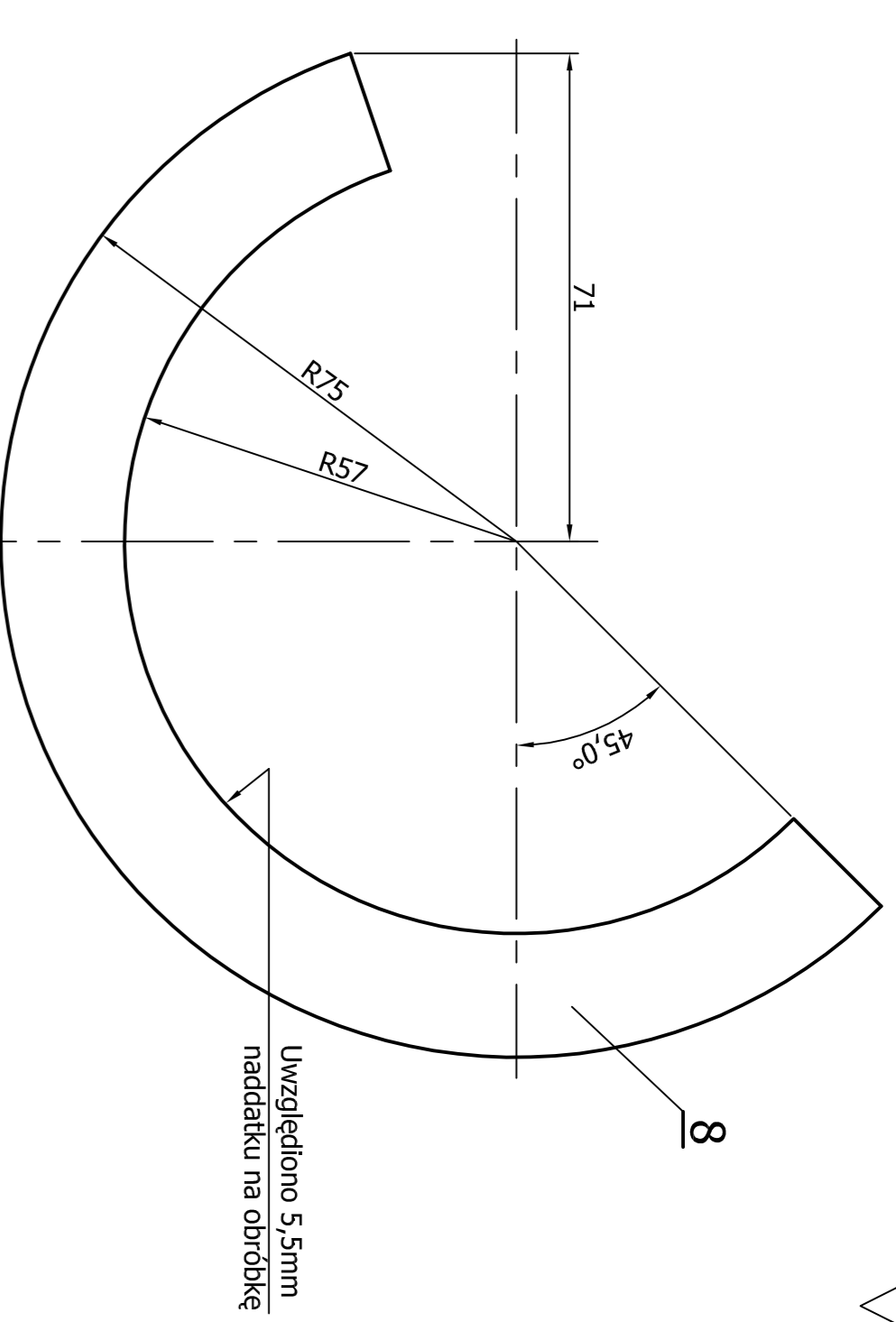
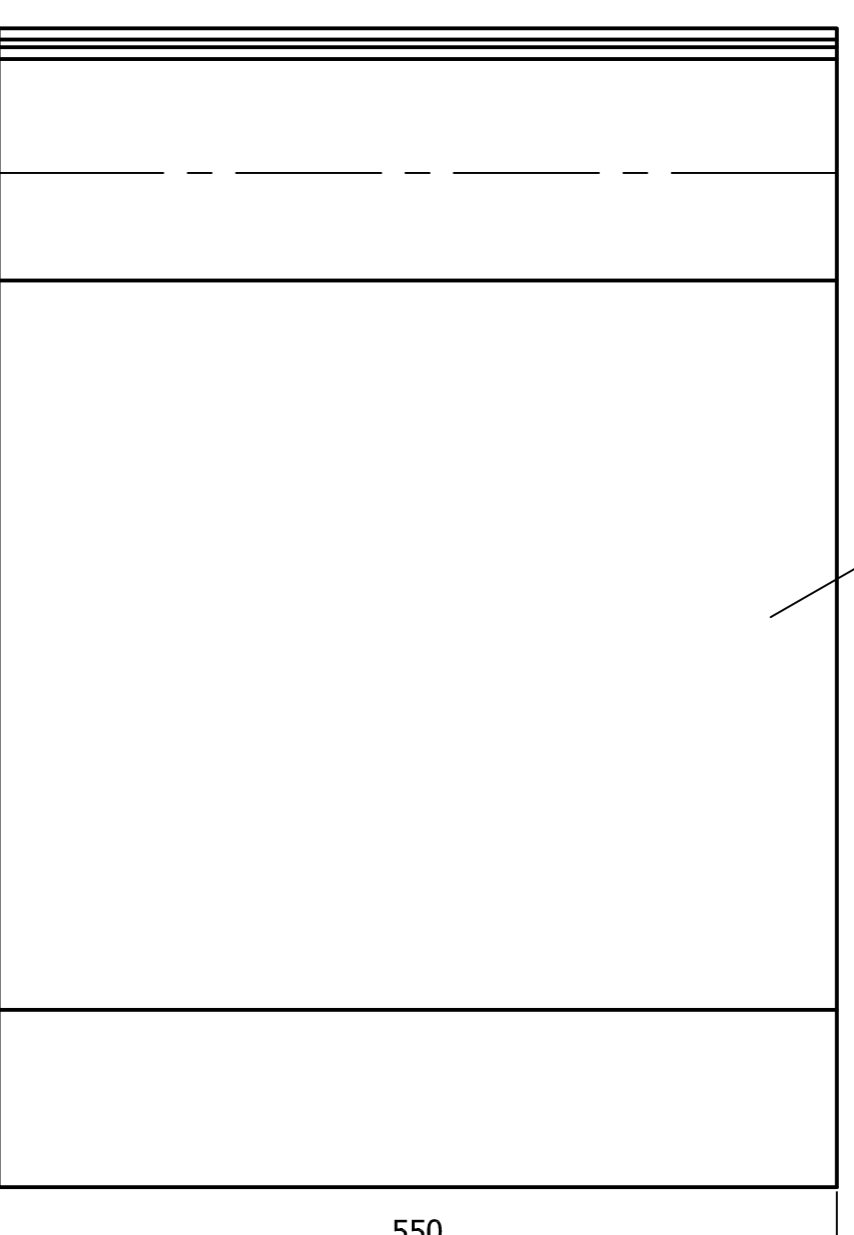
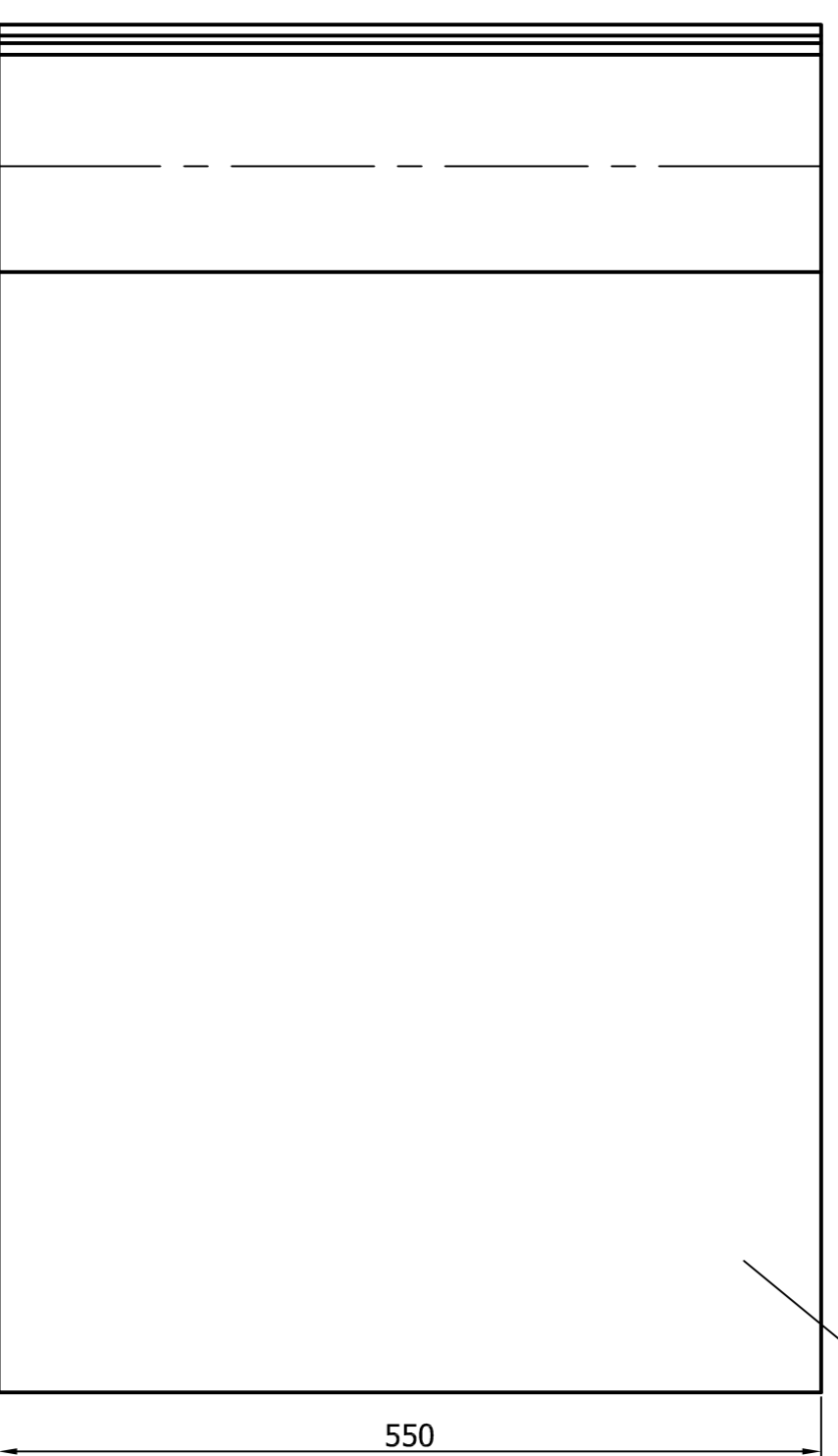
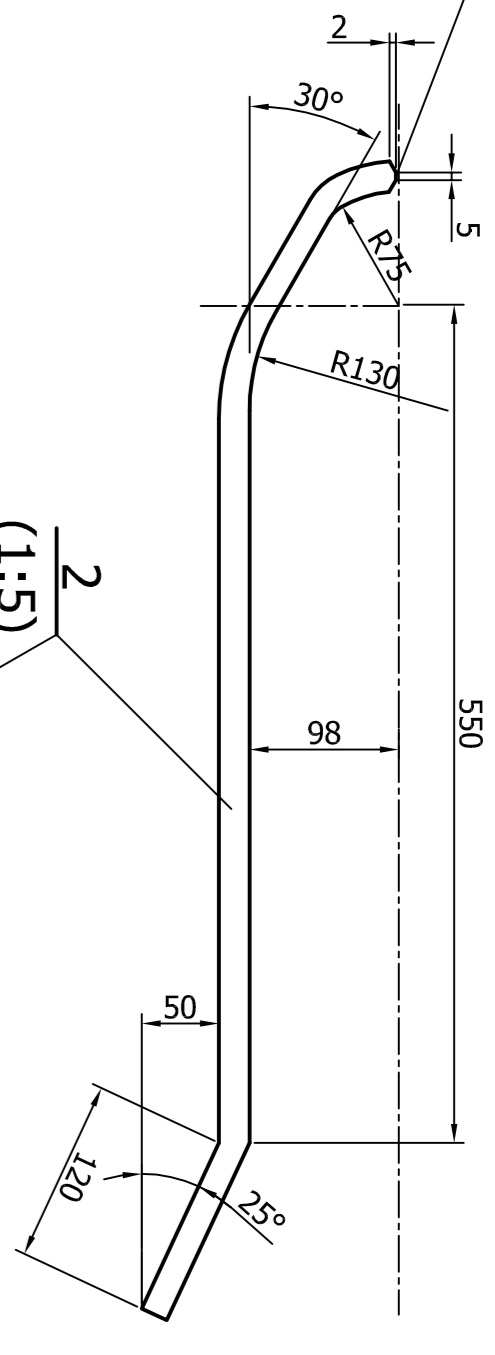
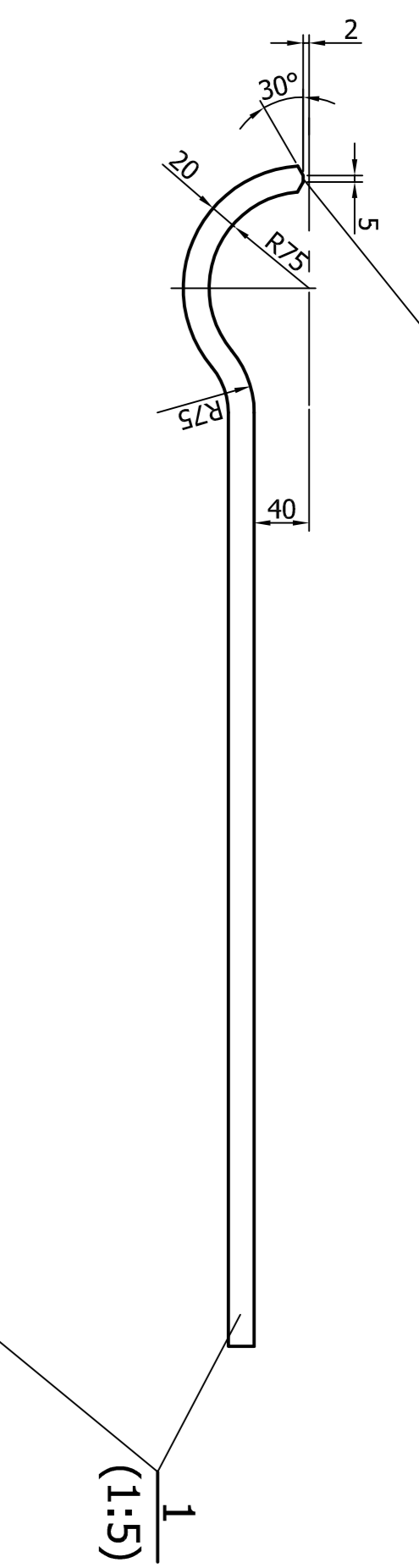

- Uwagi:**
1. Poz. 6a obowiązuje dla kruszarki 40.28.
 2. Poz. 6a obowiązuje dla kruszarki 40.27.
 3. Rys rozpatrywać łącznie z ark. I.

Poz	Nazwa	Il. szt.	Mat.	Masa (kg)	Nr rys./Norma	Nr arch
Zmiana	Nr karty	Podpis	Data	Zmiana	Nr karty	Podpis
OBIEKT		Kocub. Odrębacz-Kruszarka Mikrum.				
Zespół/część		Wahadlo art. II.				
Nr rysunku		11.002.02.000.001.1				
Material		Materiał: stop aluminium [02.2018] Kod: 110001 Zawiesić: stop Al, 1%Mg Norma: EN				
EłPOSERWIS		Podpis		Zasępn. rys. nr		
POLANIEC		Podpis		Zasępn. rys. nr		
1:1		1:1		1 - arch		
Zasępn. rys. nr		Zasępn. rys. nr		1 - 0680		
Nr ark.		Nr ark.		Nr ark.		
Il. ark.		Il. ark.		Il. ark.		
Norma DKS		Norma DKS		Norma DKS		